



**Underfloor**  
**Heating Systems Ltd**

## INSTALLATION INSTRUCTIONS



**Unit 1  
79 Friar Street  
Worcester  
WR1 2NT**

**Tel: 01905 616 928  
Fax: 01905 611 240  
E-mail: [info@underfloorheatingsystems.co.uk](mailto:info@underfloorheatingsystems.co.uk)  
Website: [www.underfloorheatingsystems.co.uk](http://www.underfloorheatingsystems.co.uk)**

## 1. Installation

### Read this entire document first!

- Pipe distance for concrete floor is c/c 200 mm to c/c 250 mm and for timber suspended floors c/c 200 mm. We also recommend 200mm for heat pumps or even 150mm for reduced flow temperature.
- Pipe to be 100 mm from the walls. Always go with flow to the cold spots first. See hand sketch for typical layout.
- Max loop length is 110 m. We recommend two people for fitting the pipe, one person that holds the coil and another person to clip the pipe into the insulation.
- Fix the pipe to the insulation with the clips provided. You need approximate 1 to 2 clips per metre of pipe.
- The manifold, wiring centre and control pack should always be located **centrally** in the building.
- RS = Room Thermostat Required, from hand sketch.
- Try to use all the pipework supplied. You will usually have waste. The **pipe is marked every metre** so you know when it is time to go back to the manifold. The loop lengths on the hand sketch are only rough estimations on what you will use.
- Pipe is normally not laid under Kitchen and Utility units.
- We recommend that you first install the manifold and the control pack as instructions provided. To fit the pipe to the manifold, cut the pipe end squarely using the plastic pipe cutter. Re-round the pipe end with the calibration tool provided, place the nut over the pipe, then the olive and finally push in the insert into the pipe and then attached to the manifold. The manifold is normally fitted 1 m above the floor level.
- If the pipe is kinked when bending, the pipe should be straightened and rearranged so that the location of the kink remains in a straight length.
- Note the lengths of pipe fitted to each circuit, pipe is marked every metre.
- Note also the room, which each circuit applies.
- Prevent people from walking over the pipes, keep tools etc away from the pipes.
- Fill the system as instructions provided. **Do not fill from the boiler filling loop. The system should be filled with water before the screed is laid.**
- It is important to purge the pipework from the **boiler to the manifold**, to avoid air being introduced into the underfloor heating system.
- Screed or chipboard flooring should be laid immediately after the pipe laying to protect the pipe.

## 1. Installation (continued)

- Hardwood timber flooring must be conditioned before fixing.
- Balance the loops as suggested in the instructions.
- Room thermostats require a 35mm back box.
- Note that the **Room Thermostats are 3 core + earth**. If you have individual controls you will have a wiring centre, position the wiring centre just above the manifold.

We have supplied you with **PRT** digital room thermostats. When the system is running make sure that the room thermostats are set at 20 degree C, the system is designed to work at 20 to 21 degree C – which is UK design temperature for inside climate. The pump speed should be set at speed 3. The mixing valve is normally set on 45 degree C for concrete floors and on 55 degree C for timber suspended floors. If for some reason the rooms are not getting warm, then it is possible to increase the flow temperature on the mixing valve.

If the system for some reason makes a noise, then there is probably a bit of air in the system. The air can be removed from the end caps on the manifolds, similar to a radiator system. Make sure that the system is operated for 24 hours before making any adjustments.

**Note, the system operates 24 hours a day during the heating season. It is cheaper to run the system this way.** The PRT room thermostats are programmable, ie you can set the room thermostats to drop 5 degree C for example at night and in the morning the system can respond quickly as it will go back to normal temperature, see instructions provided for the PRT.

Room thermostats are normally fitted 1.5 metre from the floor and near the light switch. Try to avoid direct sunlight.

Maximum heat output for underfloor heating systems are 100 W/m<sup>2</sup> for concrete floors and 70 W/m<sup>2</sup> for timber suspended floors. For any underfloor heating system to work efficiently the property needs to be built to current building regulations. Carpet and underlay together should not exceed 2.5 Tog.

If you are using the underfloor heating for a Conservatory, note that it will extend the time you can use the Conservatory for. It will not keep it at 20 degree C all year as the heat losses are higher than 100 W/sqm in a Conservatory. Usually, this is also the case if radiators would have been fitted.

Condensing boilers are very efficient with underfloor heating. For combination boilers it is always recommended to check with the boiler manufacturer if the **boiler can be fitted with a secondary pump**. Sometimes if the project is just a small flat and the combi boiler is only providing UFH and hot water, it is possible to have the UFH system without the control unit. There need to be a safety device on the boiler to prevent the end user from adjusting the flow temperature above 60 degree C.

## 1. Installation (continued)

Underfloor heating systems can be mixed with conventional radiator systems. Also note that the underfloor heating system needs to be a **complete separate system**, ie the flow and return for the underfloor heating needs to go all the way back to the boiler. If you do have radiators in your system, we recommend independent control from the boiler, ie not together with the underfloor heating.

We recommend a **minimum of 50 mm of Polyurethane** insulation for the underfloor heating system. This is very high quality insulation and can be used for both concrete and timber suspended floor constructions.

Note we do not supply the insulation. Any builder's merchant will have Celotex or Kingspan insulation in stock. The quote is based on clipping the pipe direct to the insulation board. We do supply pipe clips. We recommend **65 mm – 75 mm of screed** on top of the insulation for concrete floors.

The screed must be allowed to dry for a minimum of **4 to 6 weeks** before the heating is operated. As the system is used for the first time, the mixing valve must be set to minimum setting to let the moisture in the screed to dry out. The temperature should be increased by two degrees every day until the mixing valve is set at 45°C. Floorboards must have moisture content lower than 7 % before they are installed. We do not recommend floorboards thicker than 25 mm, see website link under technical for more information about floorboards. **Always check with the manufacturers of any floor finish that it will work with underfloor heating. It is important that not any floor finish is laid on the concrete until it is 100 % dry.**

For stone and ceramics tiles it is recommended that flexible adhesives and grout are used. Avoid underlays for carpet with felt and rubber crumb type. With Vinyl check the vinyl floor manufacturer that it works with underfloor heating. Laminate flooring should have an expansion gap for movement.

As WC and Bathrooms are very small areas, extra heat might be needed. **Therefore it is standard practice to install towel rails in these areas, combined with the underfloor heating.**

**If there are metal parts in the system it should be flushed with Fernox or similar product. For a normal UK size property (Four Bedroom house) 22 mm flow and return to the manifold is suitable, for larger properties use 28 mm flow and return. We highly recommend that the plumber installs isolating valves before they connect the pipework to the manifold from the boiler, in case the pump needs servicing or the mixing valve needs cleaning out.**

## 2. Filling the System

**Before the screed is laid the system must be filled with water and fully vented of air.** This can be best achieved using mains pressure through the two filling valves at the end of the manifolds. All valves should be closed and the flow filling valve connected with a hose to the mains water supply, with the return filling valve connected to a hose laid to a wastewater point.

One by one the flow and the return valves are opened and closed purging the loops of air. Ensure that all the blue caps on the return manifold are closed. Open the upper ring on the end cap 2 to 3 turns. Open the first blue cap and then open the return end cap. Wait until clear water is coming out and make sure that all the air is gone. Close the blue cap and do same for the next loop. Continue the process until all the loops are fully vented of all the air. Close the end caps when done.

When this is completed and the filling valves closed off, the pumps should be run for five minutes and the air vented again at the air bleed valve on the filling valves until all air is bled from the system. **Do not fill the system from the boiler filling loop.**

The system should be pressure tested with 5 bar for 24 hours before screeding.

The manifolds are supplied with options for individual control for each room. On the return manifold (the blue caps), actuators can be mounted for individual control. If a programmable room thermostat with a two port valve is controlling the system and there is no individual control, the “blue caps” should be left open. The flow manifolds are supplied with flow gauges. To adjust the flow gauges, use the key provided with the manifolds. See instructions included in the manifold box on how to adjust the flow meters.

The following is an approximate guide, as how far each loop should be adjusted;

<u>Size of Loop</u>	<u>Percentage Open</u>
10 – 30 metres	30 % open
40 – 60 metres	50 % open
60 – 90 metres	75 % open
90 – 100 metres	100 % open

If the return manifold is not getting warm, there is either air in the system or the flow and the return from the boiler is not correct fitted to the mixing valve. Run the pump on speed 3. The system must be on for 24 hours to confirm that all the loops are working. **Also, check that the correct room thermostat is controlling correct actuator.**

**Note, if there is a risk for the air temperature dropping below freezing, then you must protect the pipes and manifolds from freezing conditions. It is always recommended to lay screed on top of the pipes as soon as they have been pressure tested.**

### 3. Manifold Assembly



- 1) Attach manifold to wall.
- 2) Fit ball valves to manifold, attach the end with the loose nut (remember the washers!).
- 3) Remove loose nuts from adaptors and screw adaptors into fixed end of ball valves (remember the washers!), tighten using water pump pliers.
- 4) Re-fit loose nuts to adaptors.
- 5) Assemble pump & mixing valve as shown and attach to loose nuts of adaptors (remember washers!).
- 6) Connect supply pipework to mixing valve using  $\frac{3}{4}$ " male iron compression fittings .

**FRONT CONNECTION IS 'RETURN'  
REAR CONNECTION IS 'FLOW'**

## 4. Commissioning

- 1) Screed or chipboard flooring should be laid immediately after pipelaying to protect the pipe.
- 2) Concrete screed floors must be cured before any heat is applied, a general rule of thumb is to allow 1 day per 2 millimetres of screed.
- 3) Timber floor with drymix infill can have heat applied immediately, the drymix must be dried completely before laying the flooring.
- 4) Hardwood timber flooring must be 'conditioned' before fixing.
- 5) It is important to purge the pipework from the boiler to the manifold, to avoid air being introduced into the underfloor heating system.
- 6) Fit actuators to valves after connecting the control wiring.
- 7) It is important that the actuators are screwed tightly on to the valve.
- 8) Initially start the system with the thermostatic valve set at min (35°C).
- 9) Increase the setting by 2° per day, up to a maximum of 50° for concrete floors, max 65° for timber floors.
- 10) The flow & return from the boiler should be connected to the manifold connections shown using compression couplings.
- 11) NOTE. When first starting up the system it may take 12-24 hours for the heating effect to become apparent!

## 5. Maintenance

- 1) It is recommended that the following maintenance be carried out annually.
- 2) Check that all actuator locating rings are tightened firmly and that actuators are not loose.
- 3) Remove end plug from pump and check that pump rotates when energised.
- 4) Turn up thermostats and check that actuators move into open position also check flow gauges are indicating. If not, de-pressurise manifold, remove indicator, clean and replace, re-pressurise manifold.

**6. Electrical: 1x wiring centre (less than 8 thermostats per manifold).**

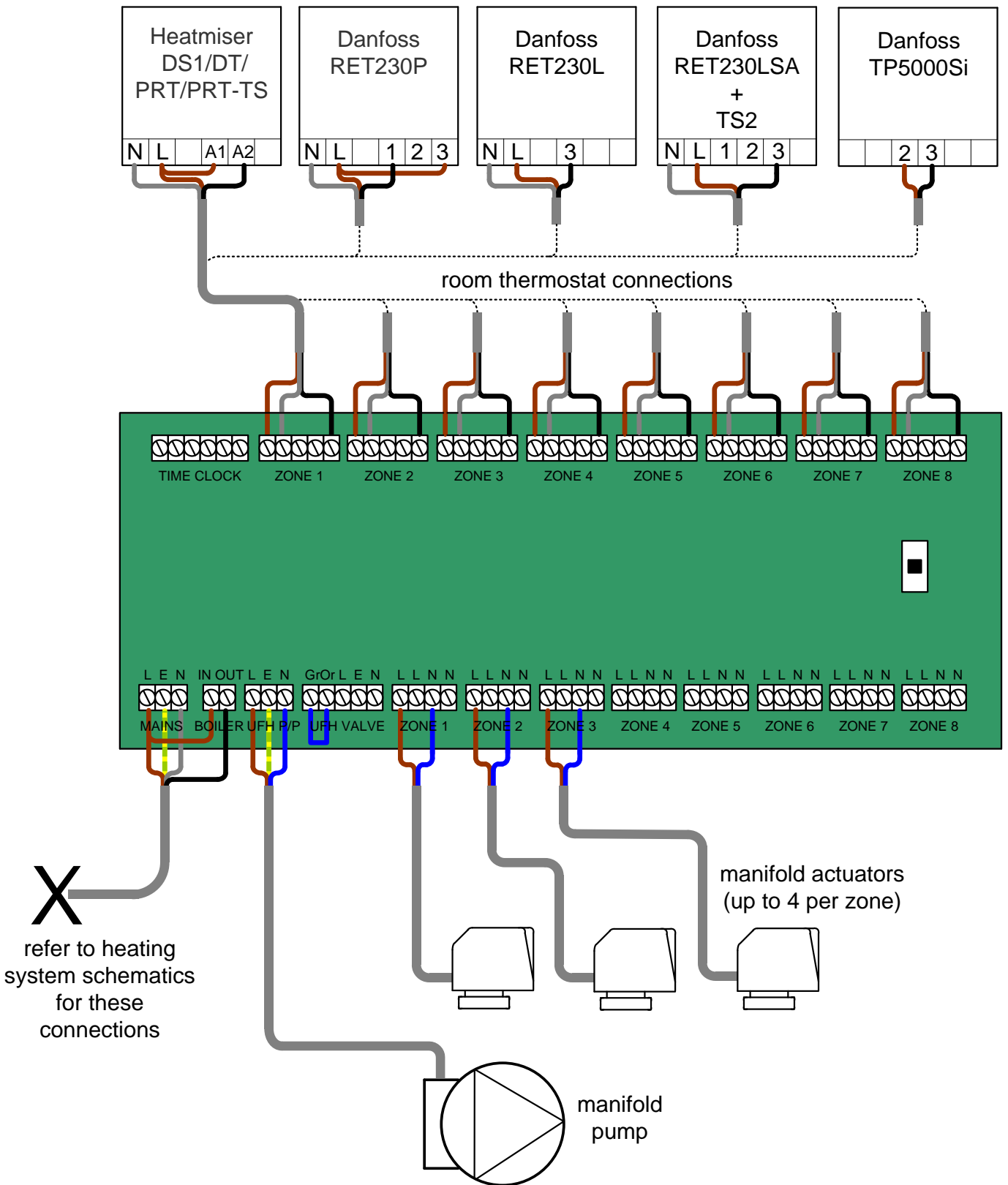

7. Electrical: 2x wiring centre (more than 8 thermostats per manifold).

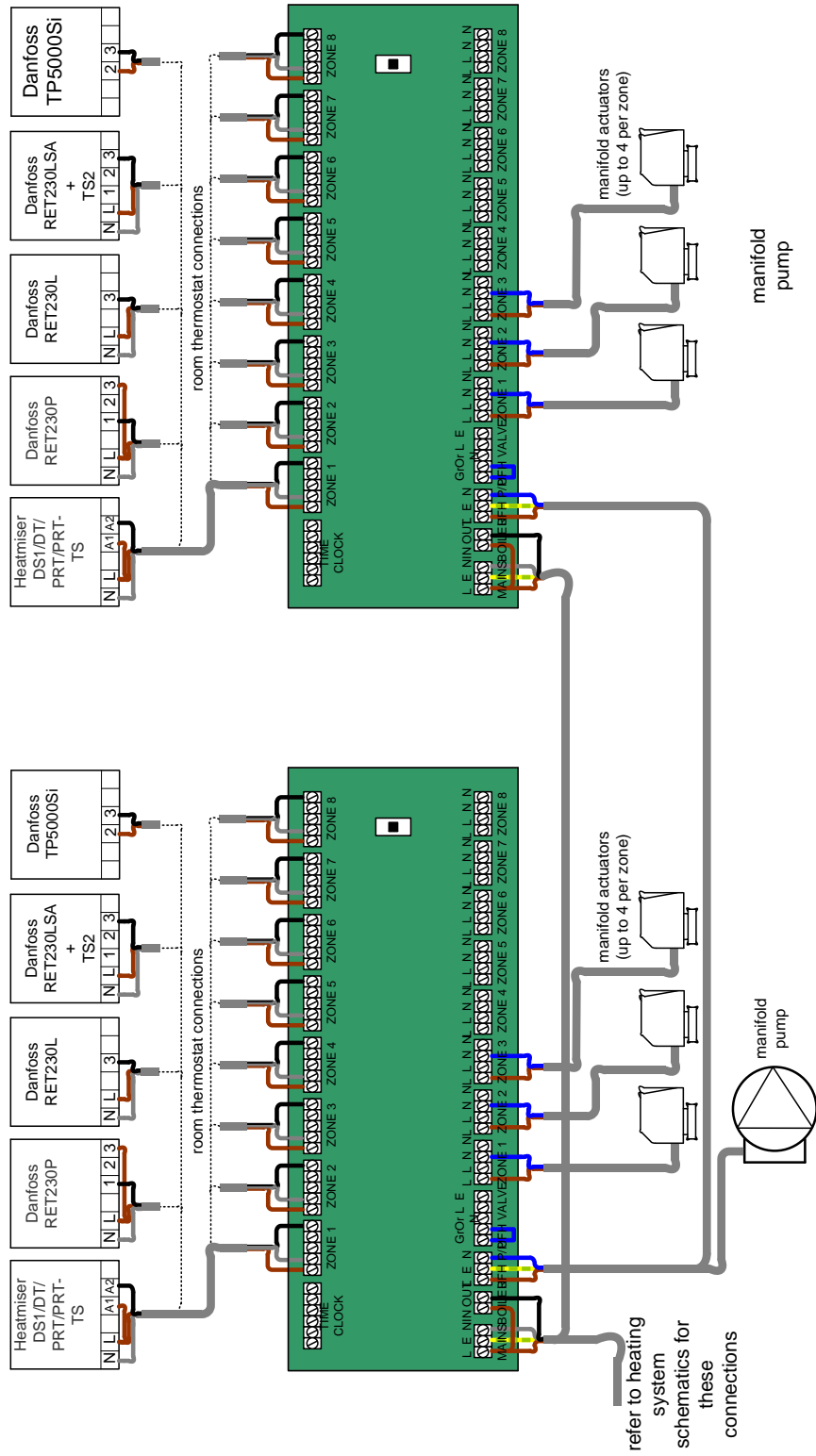

**8. Electrical: SYSTEM BOILER + hot water + underfloor heating.**

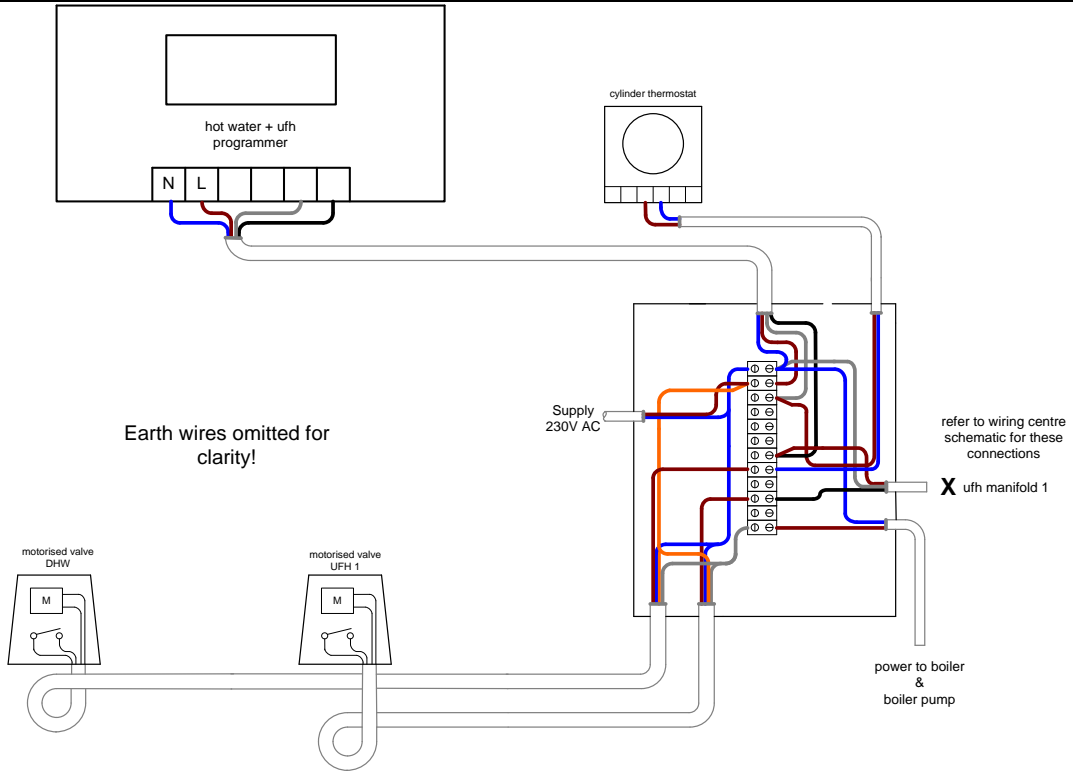

**8a. Electrical: SYSTEM BOILER + hot water + 2x underfloor heating.**

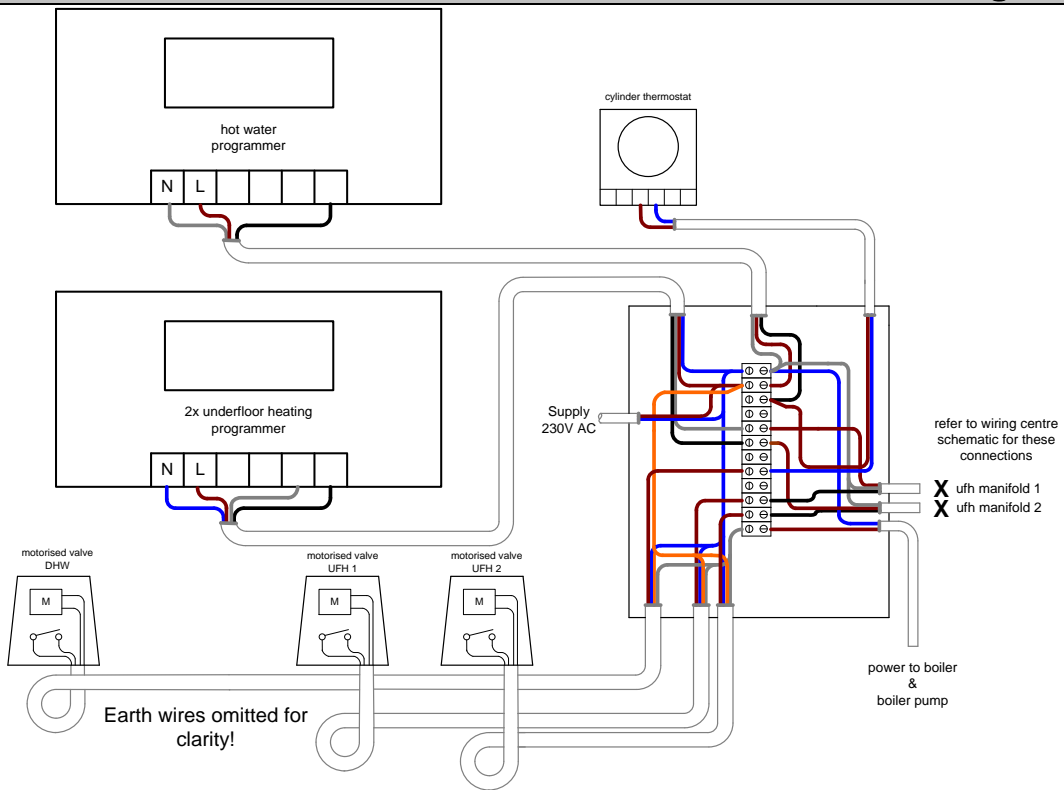

## 9. Electrical: SYSTEM BOILER + hot water + radiators + underfloor heating.

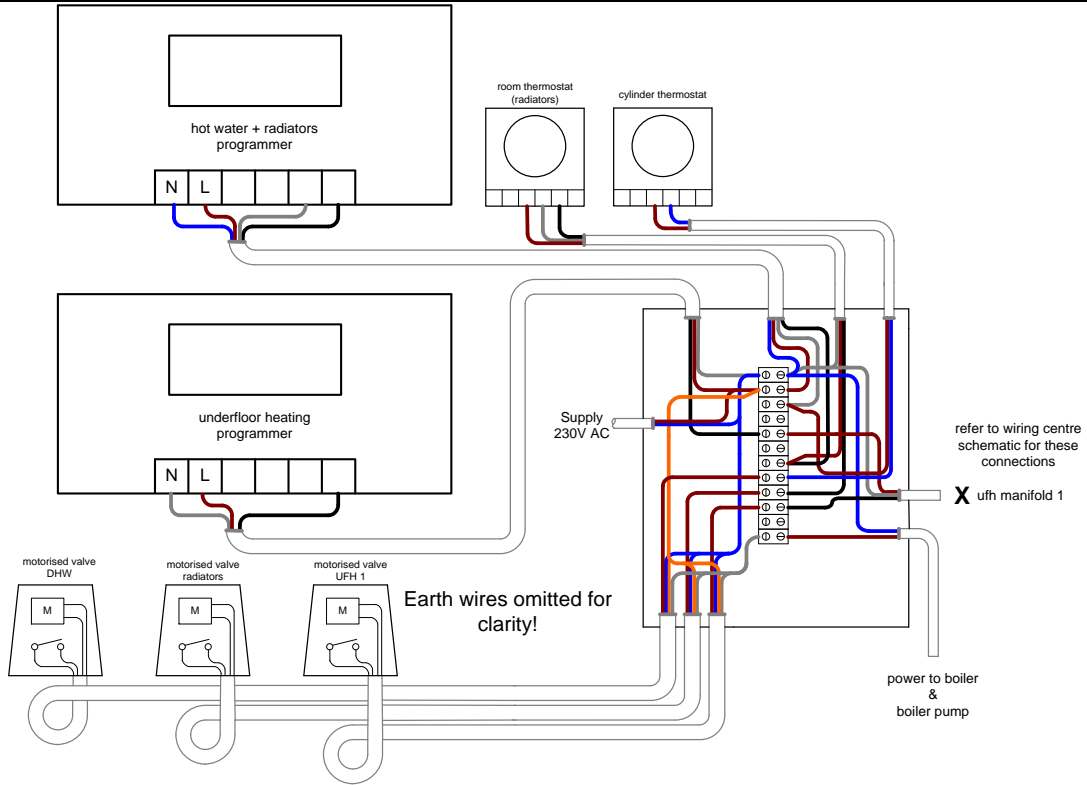

## 9a. Electrical: SYSTEM BOILER + hot water + radiators + 2x underfloor heating.

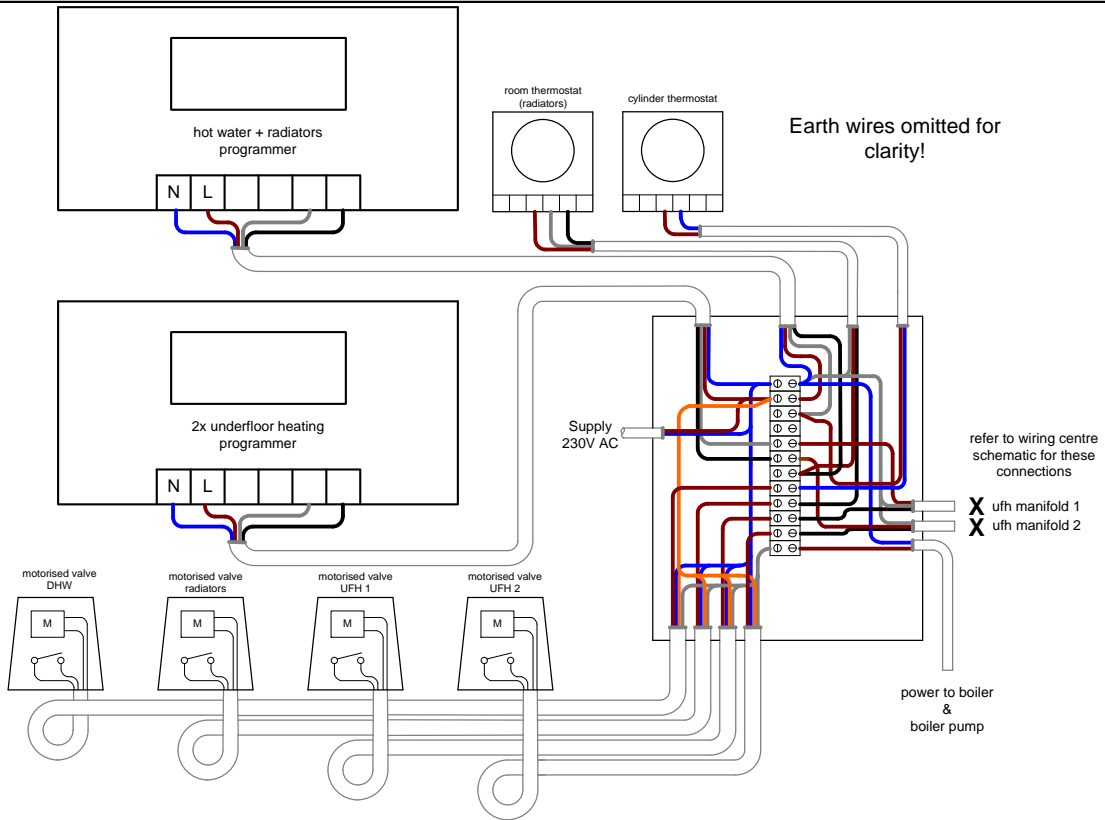

# 10. Electrical: COMBINATION BOILER + underfloor heating.

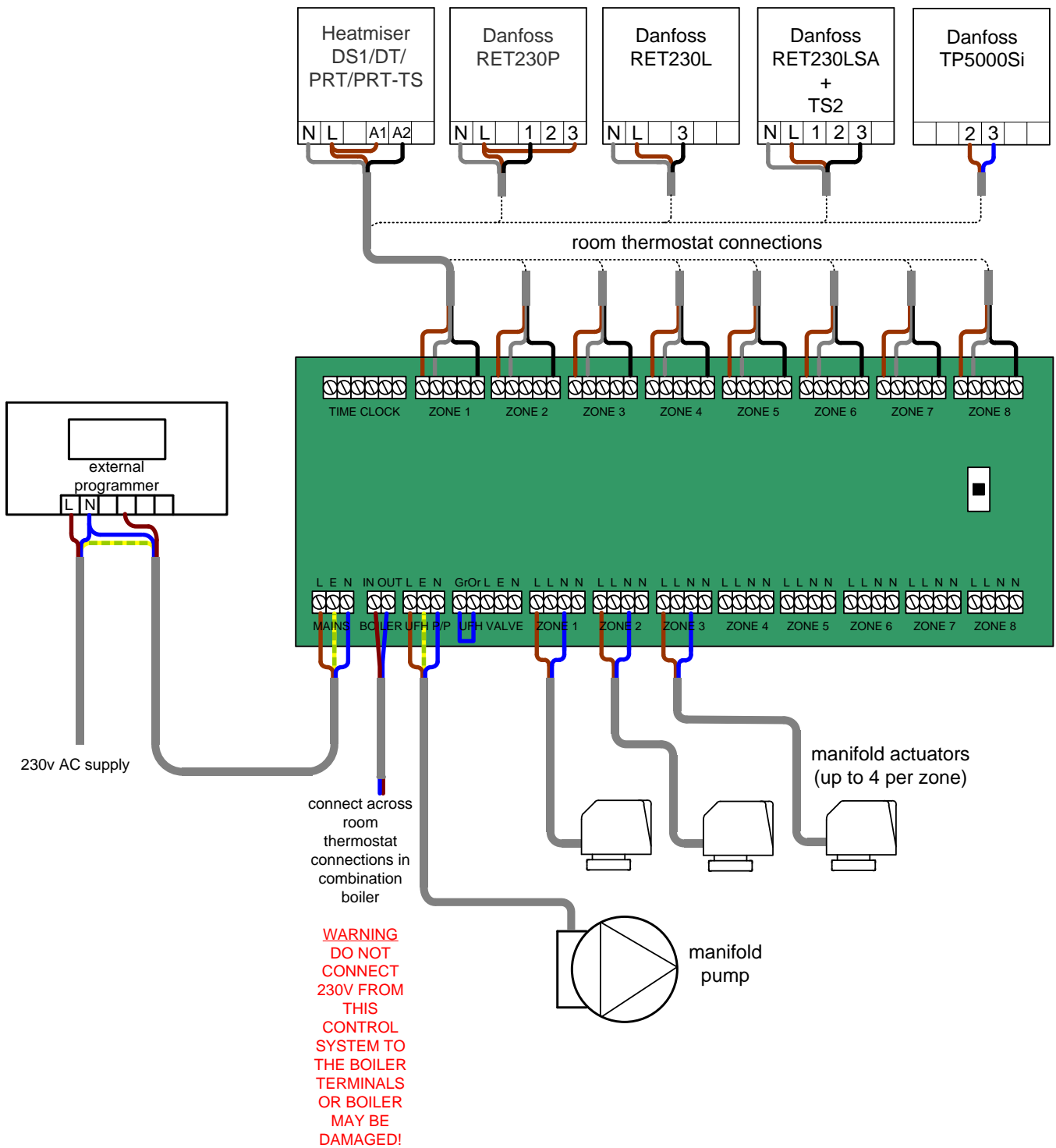

# 11. Electrical: COMBINATION BOILER + radiators +underfloor heating.

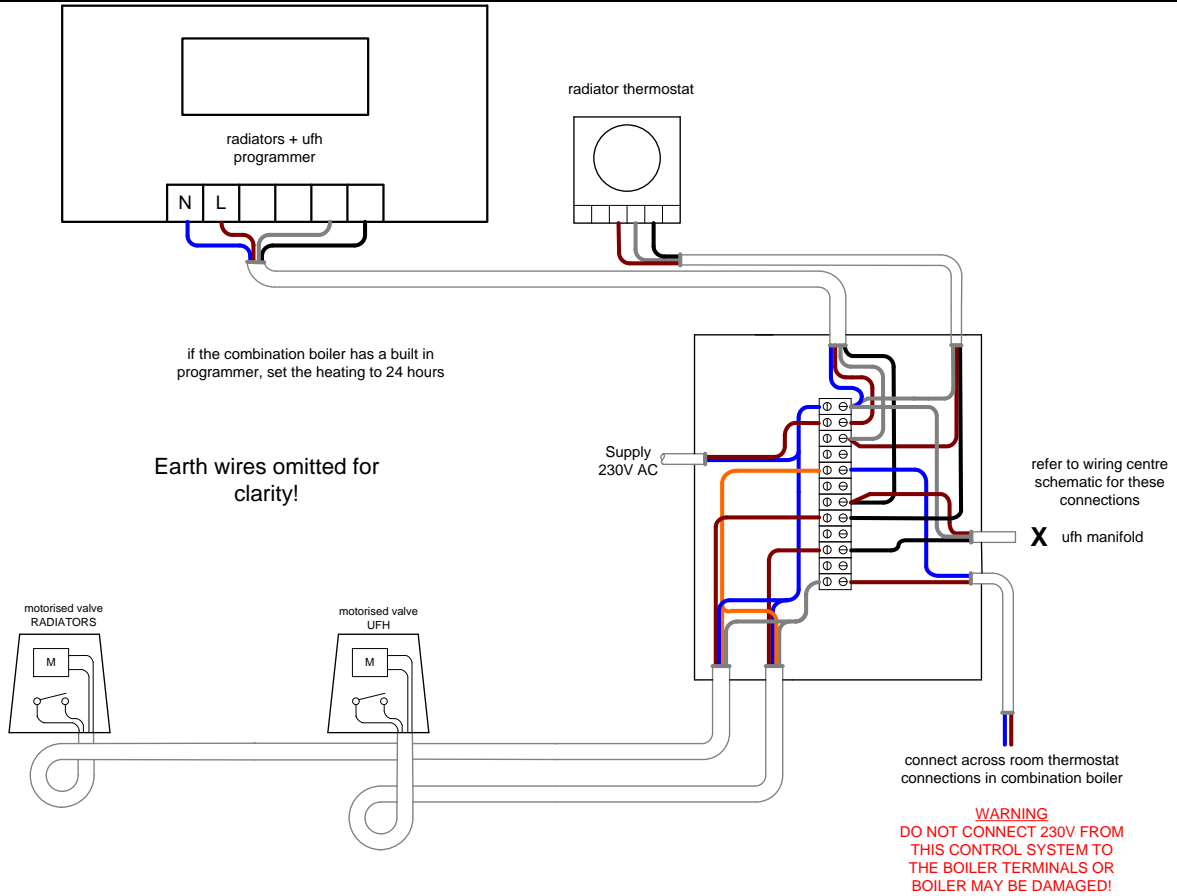

# 11a: Electrical: COMBINATION BOILER + 2x underfloor heating.

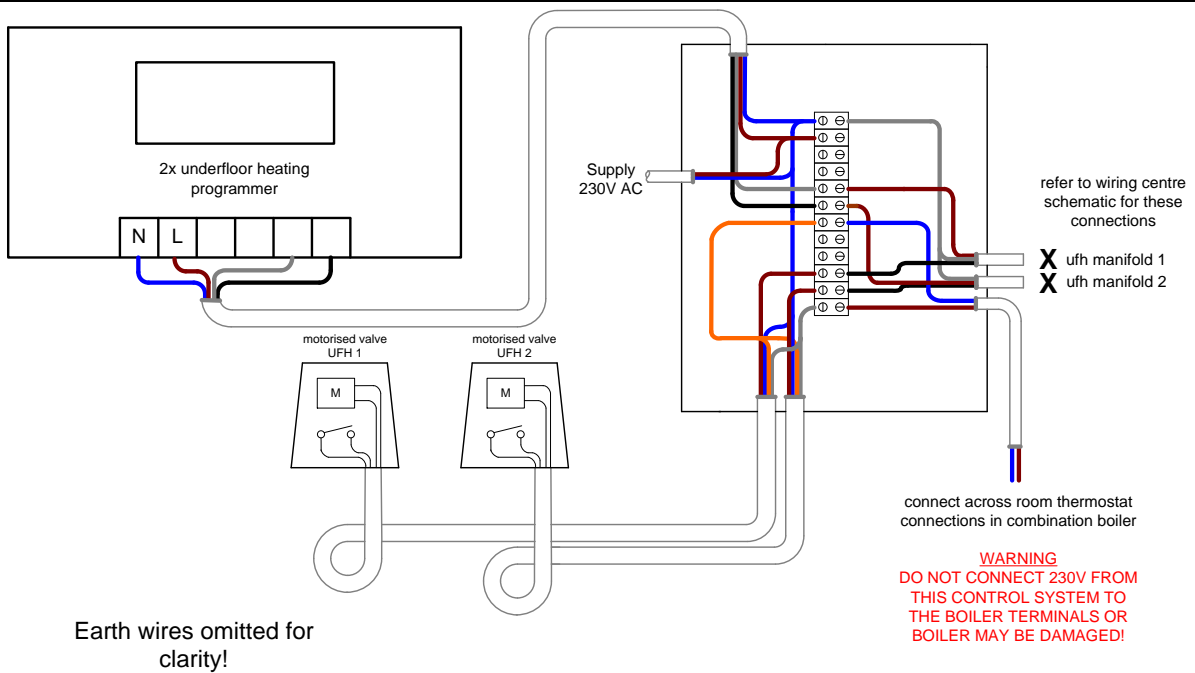

12. System schematic.

Schematic for system boiler & underfloor heating + hot water

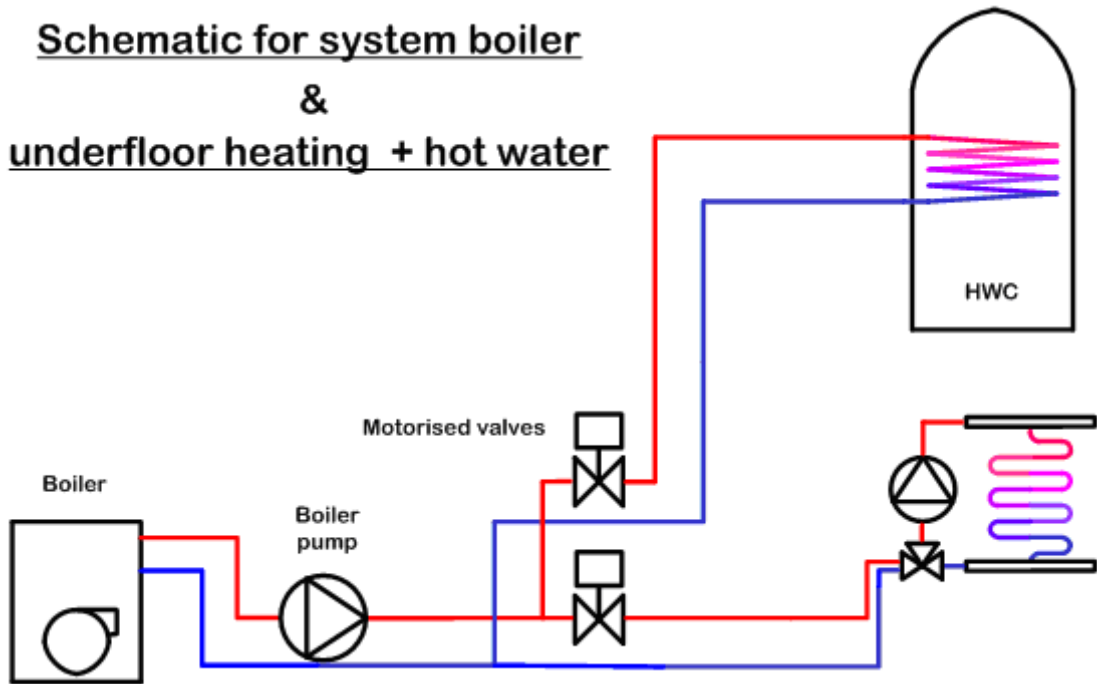

Schematic for system boiler & UFH + radiators + hot water

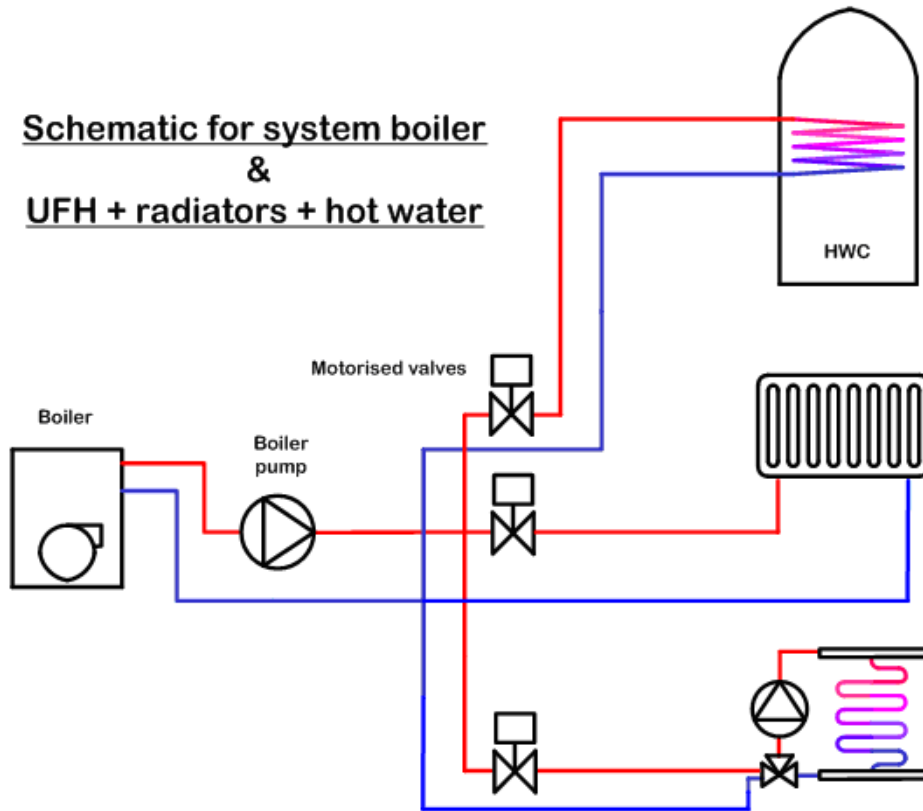

13. System schematic.

**Schematic for system boiler  
&  
2x UFH zones + hot water**

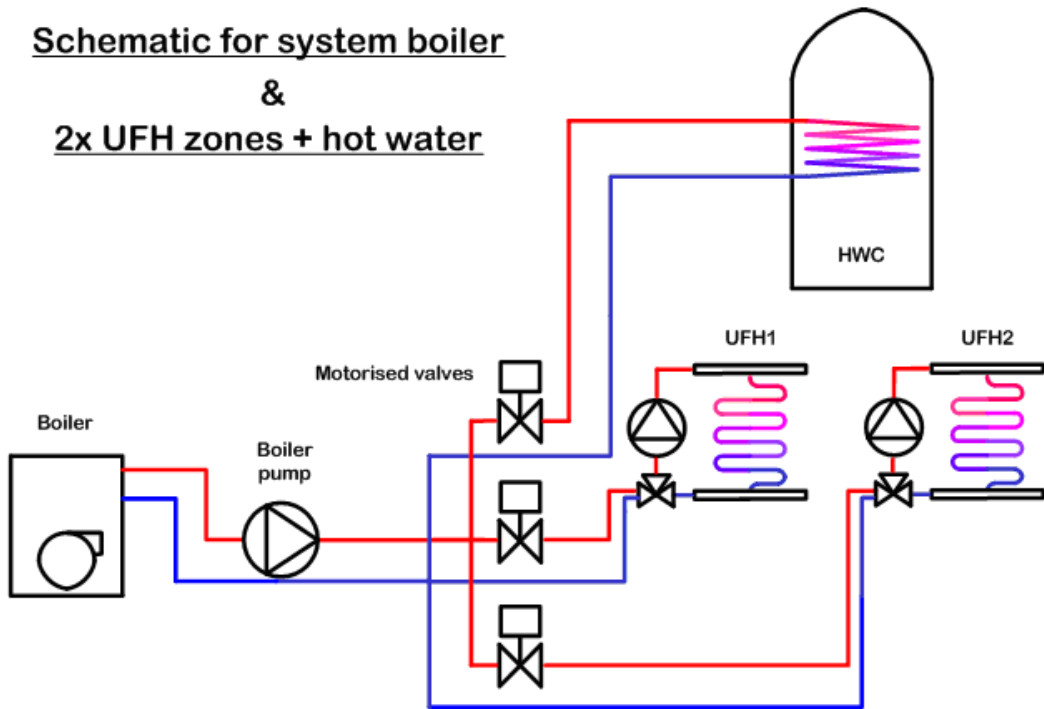

**Schematic for system boiler  
&  
2x UFH zones + radiators + hot water**

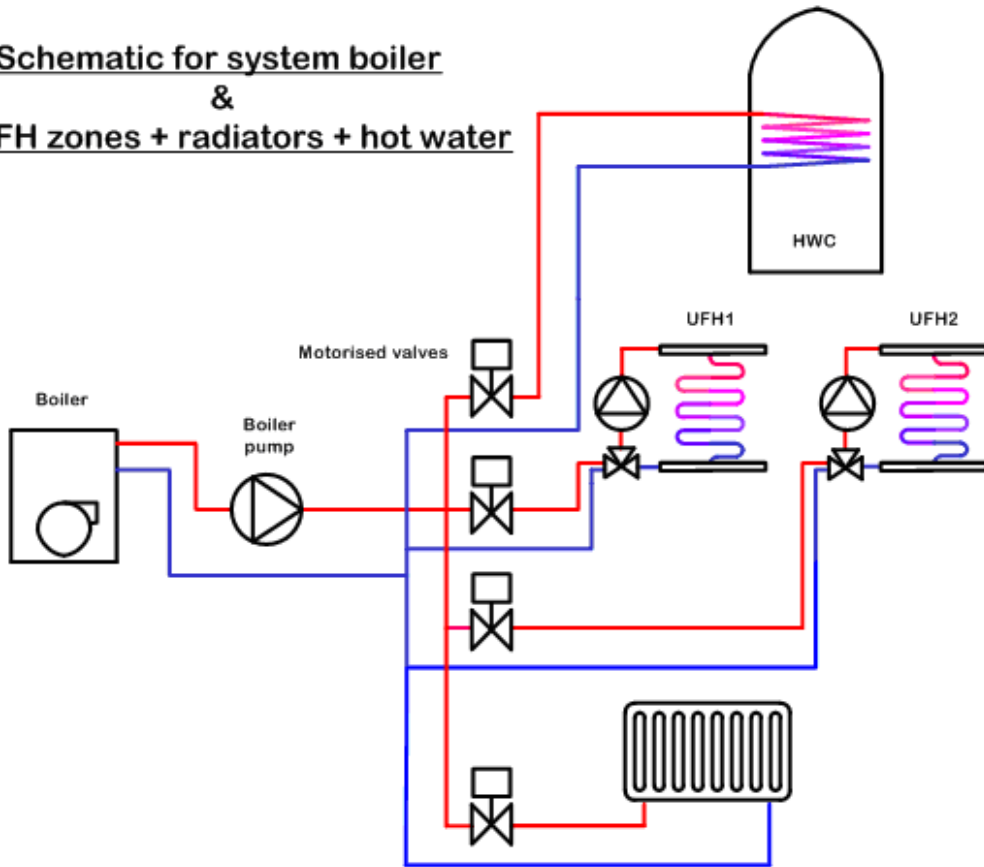

14. System schematic.

Schematic for gas combination boiler  
&  
underfloor heating + radiators

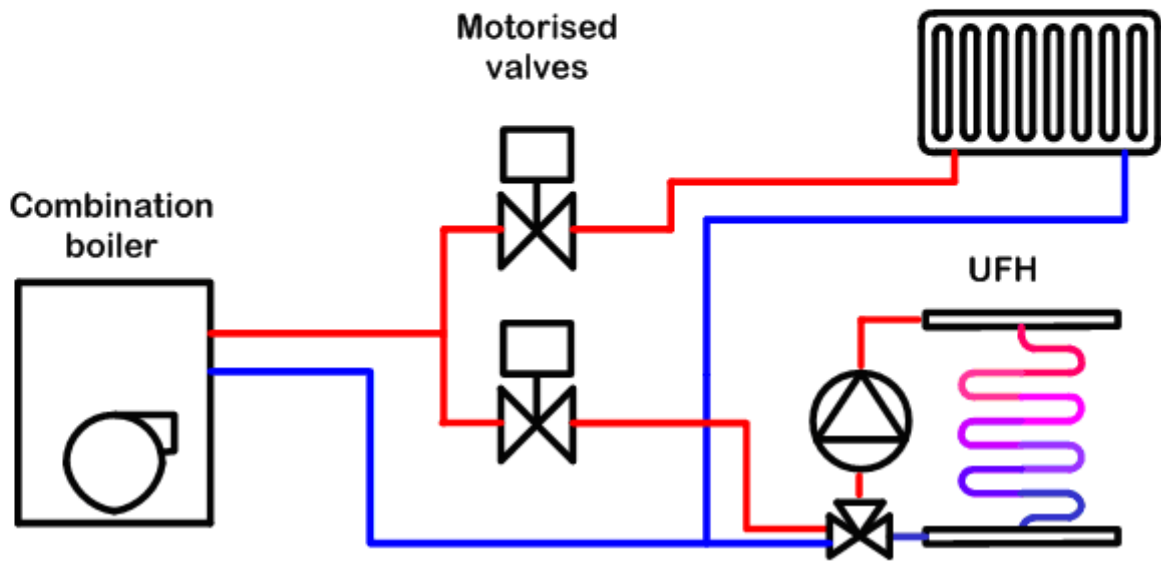

# 15. Typical Pipe Layout

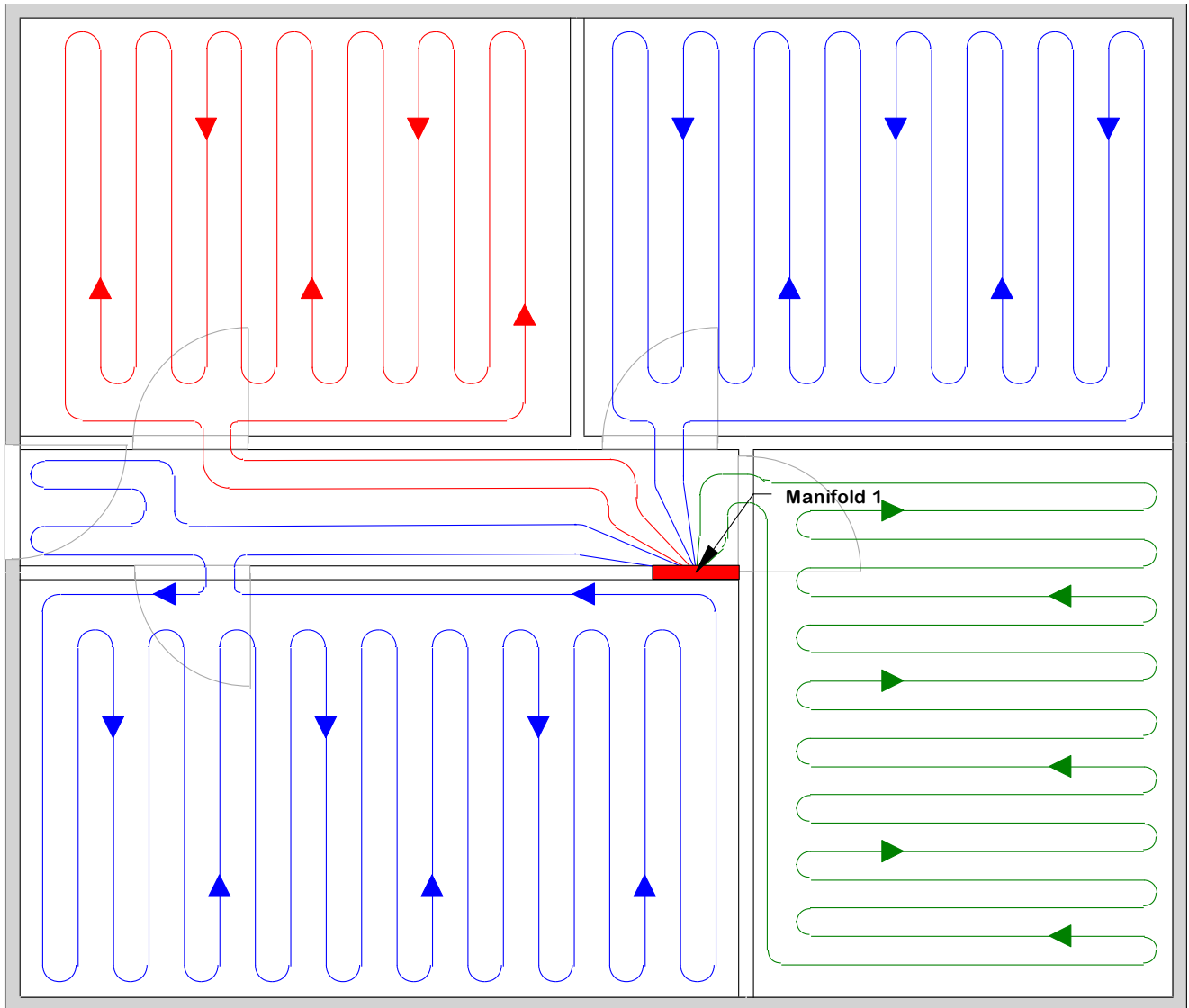

## 16. Floor Types

### Timber Suspended Floor Between Joists

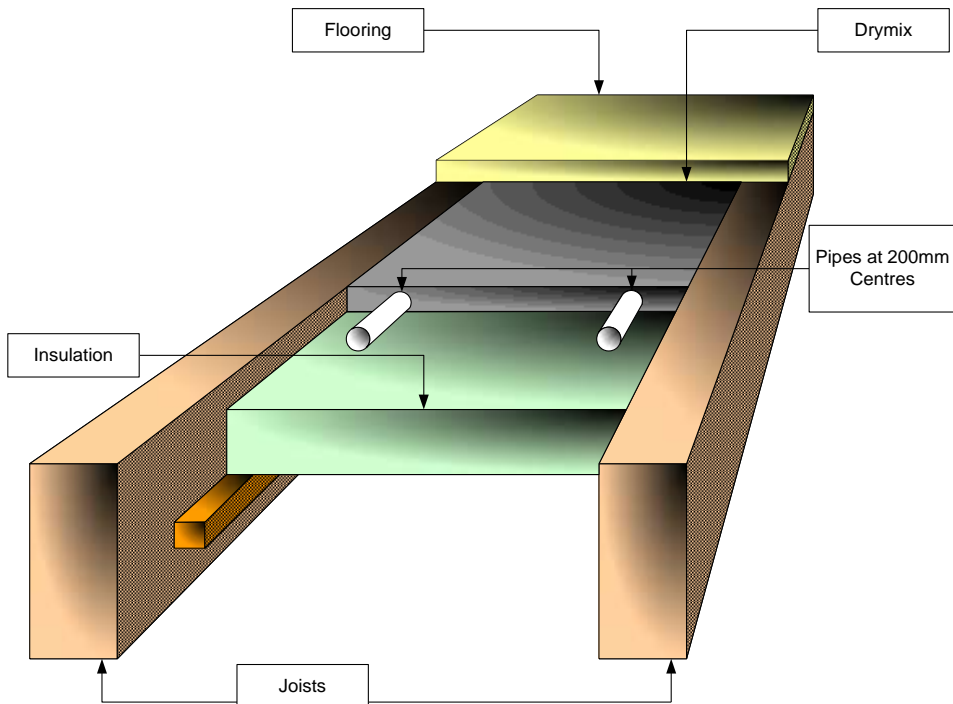

The Drymix is needed for Ground Floor, older buildings and if concrete floor and timber suspended floor are on the same floor. For First Floor applications when property is built to current building regulations an air gap is fine, still good to use the drymix as will give out more heat.

### Concrete Floor with Staples

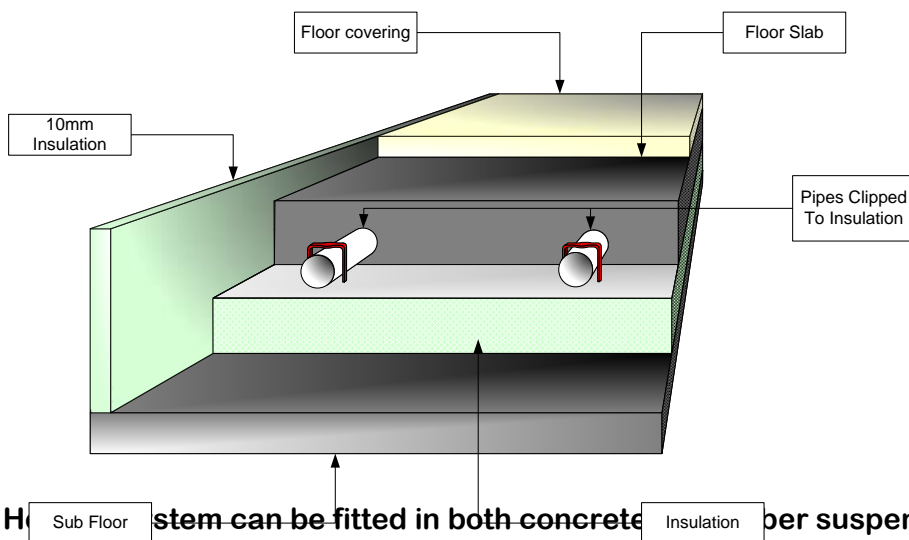

The Underfloor Heating system can be fitted in both concrete and timber suspended floors. See picture above. For other floor constructions please contact us and we will explain installation procedure, for example you can also do a floating floor. **Also note that there are many options to fit underfloor heating in timber suspended floors, contact us for more information.**

In concrete screeded floors, the screed acts to diffuse the heat across the surface providing an even temperature at the floor surface.

Normally a concrete slab is laid over DPM. A 20 mm thick piece of insulation is fixed to the perimeter walls, to a height to include the depth of floor insulation and screed.

Whilst the edging insulation may be on show it is covered by wall plastering and skirting boards. We do not supply the edging strip. Use 20 mm Celotex.

Floor insulation is laid to the whole area, joints are taped to prevent the ingress of screed between the insulation boards. The floor is now ready for the underfloor heating pipework installation.

We recommend a minimum of 50 mm Polyurethane insulation. If there is not enough space for 50 mm insulation, 30 mm is recommended, but always check that you apply to current building regulations. We recommend Polyurethane as it out performs Polystyrene and it's greater density allows for use of clip fittings.

If you use Polystyrene insulation it is recommended that you install wire mesh D49 on top of the insulation and tie the pipe with cable ties to the mesh.

The pipe is laid at 200 – 300 mm centres dependent upon design. Care must be taken to protect the pipework whilst laying the screed. We recommend **65 mm – 75 mm screed to be laid over the pipes and the insulation**. Finally the floor finish is added.

Always check with the manufacturer of any floor covering that it can be used for underfloor heating.

Timber suspended floors do not conduct heat as efficiently as screeded floors. This means that the heat output is less. **Note, that we can offer many different solutions for timber suspended floor, see website for more details.**

Some manufacturers use heat emission plates to try and achieve an even temperature on the floor. This is a very expensive way of installing underfloor heating in timber suspended floors and at the end of the plate the temperature is not going to be very high. Clearly there should be a cheaper solution that works without using the very expensive plates. After all, the first floor is usually timber suspended and on the first floor less heat is usually required. Also note that the first floor is supplemented by heat from the ground floor.

Our underfloor heating system is very simple and easy to install in timber suspended floors. The system is based on thousands of installations that are now working with total satisfaction.

Between the joists, a 50 mm Polyurethane insulation board is cut for a tight fit. See picture above. It is advisable to use scrap battens from building site to support the insulation from below.

The pipe is then clipped on the insulation with our special clips. Then the floor boards are laid on top of the joists. Be careful not to leave too much air space between the insulation boards and floor boards (25 mm is recommended). The joists need to be notched where needed for pipe runs.

For ground floor timber suspended or buildings 20 year or older we recommend;

To get the timber suspended floor to act as a screed floor and to give out more heat, the air gap between the insulation and the floor boards should be filled with a lightweight screed mix. This infill is normally also required if you are mixing timber suspended floor and concrete floor on the same floor level.

**We recommend the infill for all properties that are not built to current building regulations. The mix consists of 10:1 sand/cement mix or 8:1 Lytag lightweight mix on top of the insulation, with enough water to hold the mix together. The additional load imposed on the floor by the mix is approximate 18 kg/sqm. Note that the mix is not intended as load bearing, merely as a heat conductor. The thickness of the mix should be 25 mm with the pipe included in it.**

**Another solution for timber suspended floor is to use the YBS insulation foil, see below link;**

<http://www.ybsinsulation.com/superfloor.htm>