

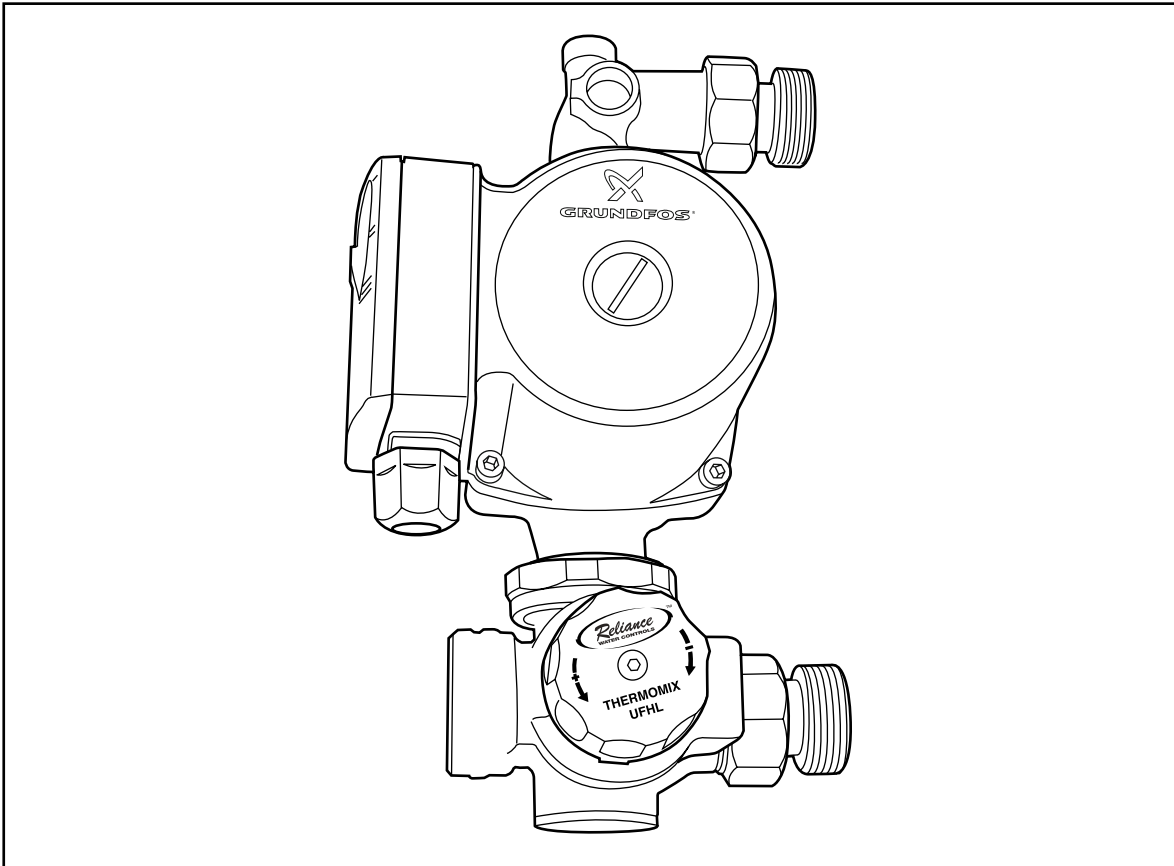

Product Specification Sheet

ThermoMix UFH Control Pack



Manifold Control Pack for providing temperature controlled mixed water to an underfloor heating system with a heat output up to 14kW.

Product Features and Benefits

- Compact bolt on unit providing quick and simple installation.
- To provide controlled mixed temperature water to underfloor heating systems with a heat output up to 14kW.
- Easy set up within the adjustable range of 35 to 65°C.
- Controls flow temperature to +/- 2°C. even with changing boiler flow and return temperatures.

ThermoMix UFH Control Pack

Description

A compact, modular control pack for underfloor heating systems up to 14kW.

Designed to be lightweight and compact in order to connect directly onto a standard manifold without the need for extra brackets or support.

The control pack consists of a mixing valve, circulating pump, return elbow, manifold adaptor and all necessary seals.

Product Range

UFHC 970 200 ThermoMix UFH Control Pack

Specifications

Maximum static pressure	16 bar
Maximum temperature	110°C
Adjustable control range	35°C to 65°C
Factory pre-set	35°C (minimum)

Materials

Valve body - Gunmetal
Seals - PTFE
O-Rings - Silicone rubber
Spring - Stainless steel

Pressure Drop Graph

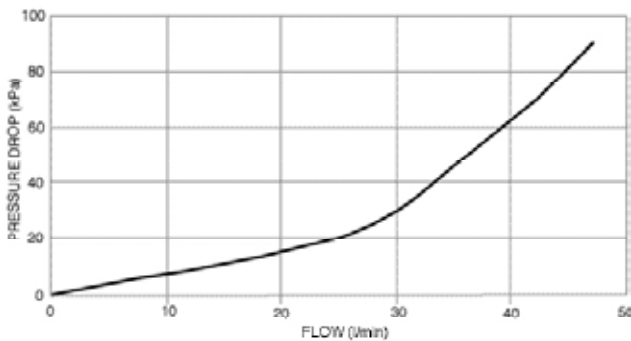

Dimensions

Guarantee

All Reliance® products undergo strict performance tests prior to despatch, and are guaranteed against faulty materials and workmanship for one year from date of purchase. This is in addition to any statutory rights.

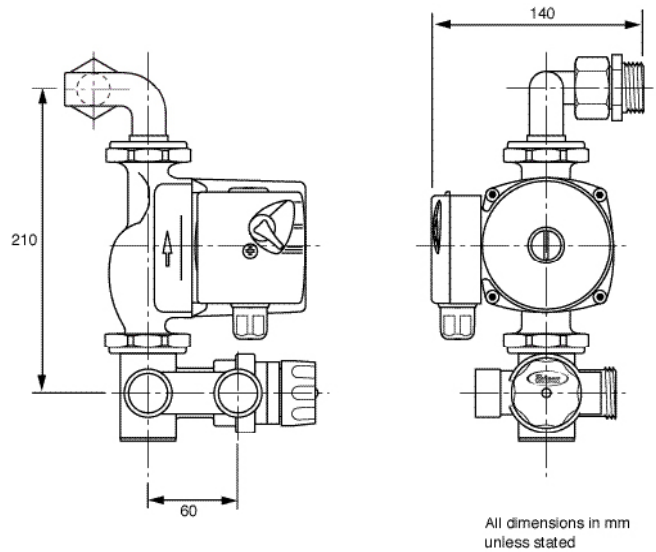

Contacts:	Sales Enquiries	Technical Support
Telephone:	+44 (0)1386 712400	+44 (0)1386 47148
Fax:	+44 (0)1386 47028	+44 (0)1386 422217
E-Mail:	sales@rwc.co.uk	technical@rwc.co.uk



Reliance Water Controls®
Worcester Road, Evesham, Worcestershire, WR11 4RA, UK
Tel: +44 (0)1386 47148 Fax: +44 (0)1386 47028 www.rwc.co.uk

