



**Underfloor
Heating Systems Ltd**

**INSTALLATION INSTRUCTIONS
ONE LARGE ZONE**



**Unit 1
79 Friar Street
Worcester
WR1 2NT**

**Tel: 01905 354 791
Fax: 01905 352 100
E-mail: info@underfloorheatingsystems.co.uk
Website: www.underfloorheatingsystems.co.uk**

1. Installation

Read this entire document first!

- Pipe distance for concrete floor is c/c 200 mm and for timber suspended floors c/c 200 mm.
- Pipe to be fitted 100 mm from the walls. Always go with flow to the cold spots first. See hand sketch or CAD for typical layout. Max loop length is 110 m.
- Max loop length is 110 m. If the pipe comes in a 200 m coil, it is sometimes much easier to work with the pipe if cut in half, ie 2 pcs of 100 m coils. Also we recommend two people for fitting the pipe, one person that holds the coil and another person to clip the pipe into the insulation.
- Fix the pipe to the insulation with the clips provided. You need approximate 1 to 2 clips per metre of pipe.
- The manifold and control pack should always be located centrally in the building.
- The Heatmiser PRT room thermostat controls the underfloor heating pump. Note, see system layout provided in this document for typical layout. Also, see wiring diagram provided. **The system needs to have independent control from the boiler, ie S-plan system with a two port valve.**
- Try to use all the pipework supplied. You will usually have waste. The **pipe is marked every** metre so you know when it is time to go back to the manifold. The 50 m and 100 m loops on the hand sketch are only a rough estimations on what you will use.
- Pipe is normally not laid under Kitchen and Utility units.
- We recommend that you first install the manifold and the control pack as instructions provided. To fit the pipe to the manifold, cut the pipe end squarely using the plastic pipe cutter. Re-round the pipe end with the calibration tool provided, place the nut over the pipe, then the olive and finally push in the insert into the pipe and then attached to the manifold. The manifold is normally fitted 1 m above the floor level.
- If the pipe is kinked when bending, the pipe should be straightened and rearranged so that the location of the kink remains in a straight length.
- Note the lengths of pipe fitted to each circuit, pipe is marked every metre.
- Note also the room, which each circuit applies.
- Prevent people from walking over the pipes, keep tools etc away from the pipes.
- Fill the system as instructions provided. **Do not fill from the boiler filling loop.**
- It is important to purge the pipework from the boiler to the manifold, to avoid air being introduced into the underfloor heating system.

1. Installation (continued)

- Hardwood timber flooring must be conditioned before fixing.
- Screed or chipboard flooring should be laid immediately after the pipe laying to protect the pipe.
- Balance the loops as suggested in the instructions.

If the system for some reason makes a noise, then there is probably a bit of air in the system. The air can be removed from the end caps on the manifolds, similar to a radiator system. Make sure that the system is operated for 24 hours before making any adjustments.

When the system is running make sure that the room thermostats are set at 20 degree C. The pump speed should be on number 3. The mixing valve is normally set 45 degree C for concrete floors and 55 degree C for timber suspended floors. If for some reason the rooms are not getting warm, then it is possible to increase the flow temperature on the mixing valve.

Maximum heat output for underfloor heating systems are 100 W/m² for concrete floors and 70 W/m² for timber suspended floors. For any underfloor heating system to work efficiently the property needs to be built to current building regulations. Carpet and underlay should not exceed 2.5 Tog.

If you are using the underfloor heating for a Conservatory, note that it will extend the time you can use the Conservatory for, not to keep it at 20 degree C all year as the heat losses are higher than 100 W/sqm in a Conservatory. Usually, this is also the case with radiators.

Condensing boilers are very efficient with underfloor heating. For combination boilers it is recommended to check with the manufacturer if the **boiler can be fitted with a secondary pump**. Sometimes if the project is just a small flat and the combi boiler is only providing UFH and hot water, it is possible to have the UFH system without the control unit. There need to be a safety device on the boiler to prevent the end user from adjusting the flow temperature above 60 degree C.

Underfloor heating systems can be mixed with conventional radiator systems. Also note that the underfloor heating system needs to be a **complete separate system**, ie the flow and return for the underfloor heating needs to go all the way back to the boiler. If you do have radiators in your system, we recommend independent control from the boiler, ie not together with the underfloor heating. See system layout below.

We recommend a **minimum of 50 mm of Polyurethane** insulation for the underfloor heating system. This is very high quality insulation and can be used for both concrete and timber suspended floor constructions.

If there are metal parts in the system it should be flushed with Fernox or similar product. For a normal UK size property (Four Bedroom house) 22 mm flow and return to the manifold is suitable, for larger properties use 28 mm flow and return. We highly recommend that the plumber installs isolating valves before they connect the pipework to the manifold from the boiler, in case the pump needs servicing or the mixing valve needs cleaning out.

1. Installation (continued)

Note we do not supply the insulation. Any builder's merchant will have Celotex or Kingspan insulation in stock. The quote is based on clipping the pipe direct to the insulation board. We do supply pipe clips. We recommend 65 mm of screed on top of the insulation for concrete floors, for timber suspended floors see website or manual. 50 mm fibre screed or Anhydrite screed can also be used.

The screed must be allowed to dry for a **minimum of 4 to 6 weeks** before the heating is operated. As the system is used for the first time, the mixing valve must be set to minimum setting to let the moisture in the screed to dry out. The temperature should be increased by two degrees every day until the mixing valve is set at 45°C. Floorboards must have moisture content lower than 7 % before they are installed. We do not recommend floorboards thicker than 25 mm, see website link under technical for more information about floorboards. Always check with the manufacturers of any floor finish that it will work with underfloor heating.

For stone and ceramics tiles it is recommended that flexible adhesives and grout are used. Avoid underlays for carpet with felt and rubber crumb type. With Vinyl check the vinyl floor manufacturer that it works with underfloor heating. Laminate flooring should have an expansion gap for movement.

As WC and Bathrooms are very small areas, extra heat might be needed. Therefore it is standard practice to install towel rails in these areas, combined with the underfloor heating.

2. Filling the System

The system must be filled with water and fully vented of air. This can be best achieved using mains pressure through the two filling valves at the end of the manifolds. All valves should be closed and the flow filling valve connected with a hose to the mains water supply, with the return filling valve connected to a hose laid to a wastewater point.

One by one the flow and the return valves are opened and closed purging the loops of air. Ensure that all the black caps on the return manifold are closed. Open the isolator on the end cap. Open the first black cap and then open the return end cap. Wait until clear water is coming out and make sure that all the air is gone. Close the black cap and do same for the next loop. Continue the process until all the loops are fully vented of all the air. Close the end caps when done.

When this is completed and the filling valves closed off, the pumps should be run for five minutes and the air vented again at the air bleed valve on the filling valves until all air is bled from the system. **Do not fill the system from the boiler filling loop.**

The system should be pressure tested with 5 bar for 24 hours before screeding.

The manifolds are supplied with options for individual control for each room. On the return manifold (the black caps), actuators can be mounted for individual control. If a programmable room thermostat with a two port valve is controlling the system and there is no individual control, the “blue caps” should be left open. The flow manifolds are supplied with flow gauges. To adjust the flow gauges, use the key provided with the manifolds. See instructions included in the manifold box on how to adjust the flow meters.

The following is an approximate guide, as how far each loop should be adjusted;

<u>Size of Loop</u>	<u>Percentage Open</u>
10 – 30 metres	30 % open
40 – 60 metres	50 % open
60 – 90 metres	75 % open
90 – 100 metres	100 % open

If the return manifold is not getting warm, there is either air in the system or the flow and the return from the boiler is not correct fitted to the mixing valve. Run the pump on speed 3. The system must be on for 24 hours to confirm that all the loops are working.

Note, if there is a risk for the air temperature dropping below freezing, then you must protect the pipes and manifolds from freezing. It is always recommended to lay screed on top of the pipes as soon as they have been pressure tested.

3. Manifold Assembly

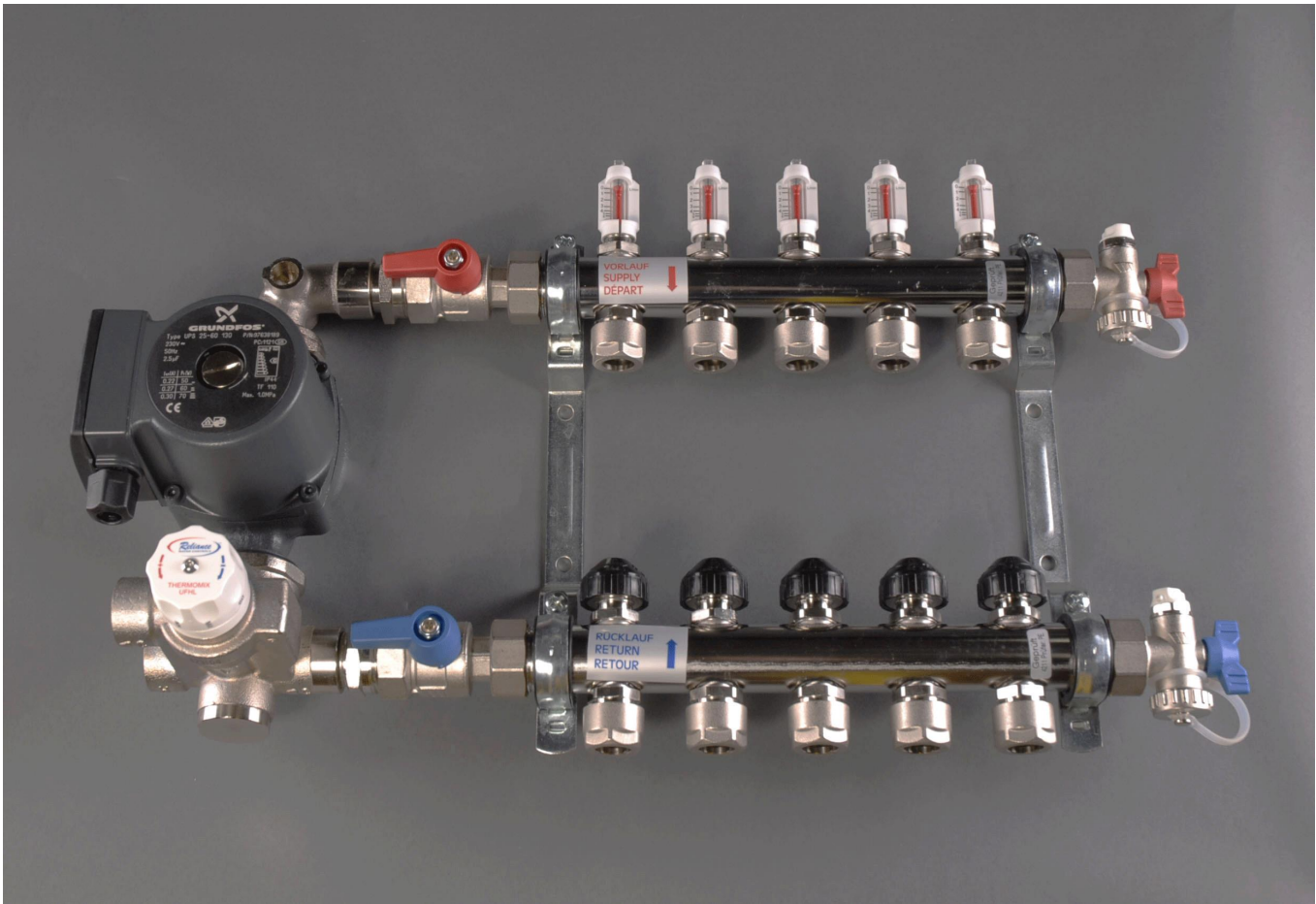

- 1) Attach the manifold to wall.
- 2) Fit ball valves to manifold (remember the washers!).
- 3) Tighten using water pump pliers.
- 4) See instruction that comes with the mixer pack.
- 5) Assemble pump & mixing valve as shown (remember washers!).
- 6) Connect supply pipework to mixing valve using $\frac{3}{4}$ " male iron compression fittings .

FRONT CONNECTION IS 'RETURN – TO THE HEATING SOURCE
REAR CONNECTION IS 'FLOW' – TO THE HEATING SOURCE

4. Commissioning

- 1) Screed or chipboard flooring should be laid immediately after pipe laying to protect the pipe.
- 2) Concrete screed floors must be cured before any heat is applied, a general rule of thumb is to allow 1 day per 2 millimetres of screed.
- 3) Timber floor with drymix infill can have heat applied immediately, the drymix must be dried completely before laying the flooring.
- 4) Hardwood timber flooring must be 'conditioned' before fixing.
- 5) It is important to purge the pipework from the boiler to the manifold, to avoid air being introduced into the underfloor heating system.
- 6) Initially start the system with the thermostatic valve set at min (35°C).
- 7) Increase the setting by 2° per day, up to a maximum of 50° for concrete floors, max 65° for timber floors.
- 8) The flow & return from the boiler should be connected to the manifold connections shown using compression couplings.
- 9) NOTE. When first starting up the system it may take 12-24 hours for the heating effect to become apparent!

5. Electrical

- 1) Thermostat position in the room is not critical but positions affected by the sun should be avoided, mounting height approx. 1.5M.
- 2) The room thermostat is used to switch the pump, see wiring details provided.

6. Electrical

TYPICAL ELECTRICAL CONNECTION SINGLE ZONE UFH + EXISTING S PLAN SYSTEM + SYSTEM BOILER

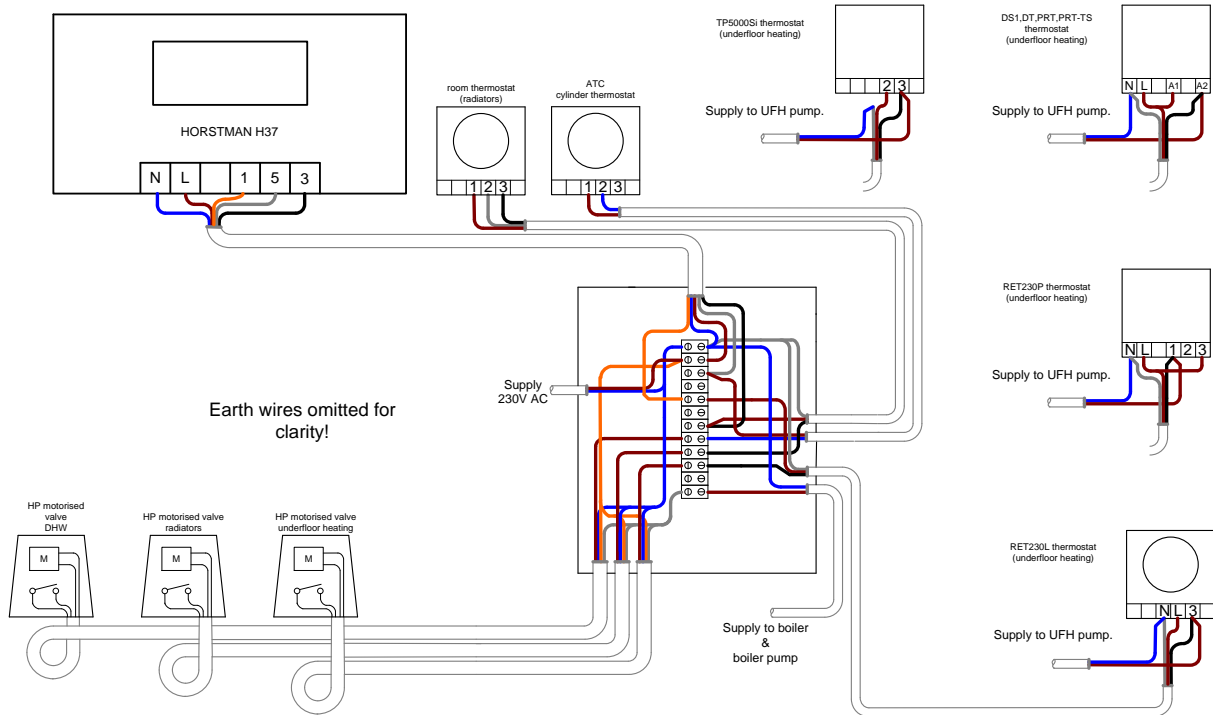

TYPICAL ELECTRICAL CONNECTION SINGLE ZONE UFH + RADIATORS + COMBINATION BOILER

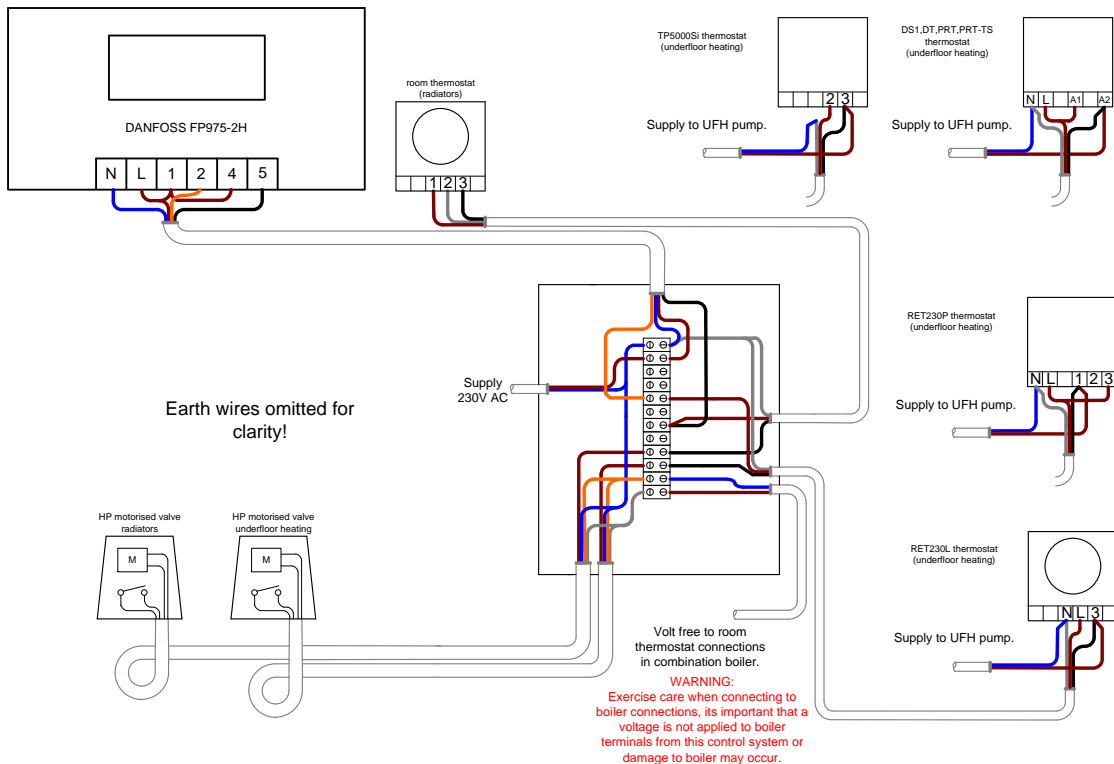

7. System schematics.

Schematic for system boiler
&
UFH + radiators + hot water

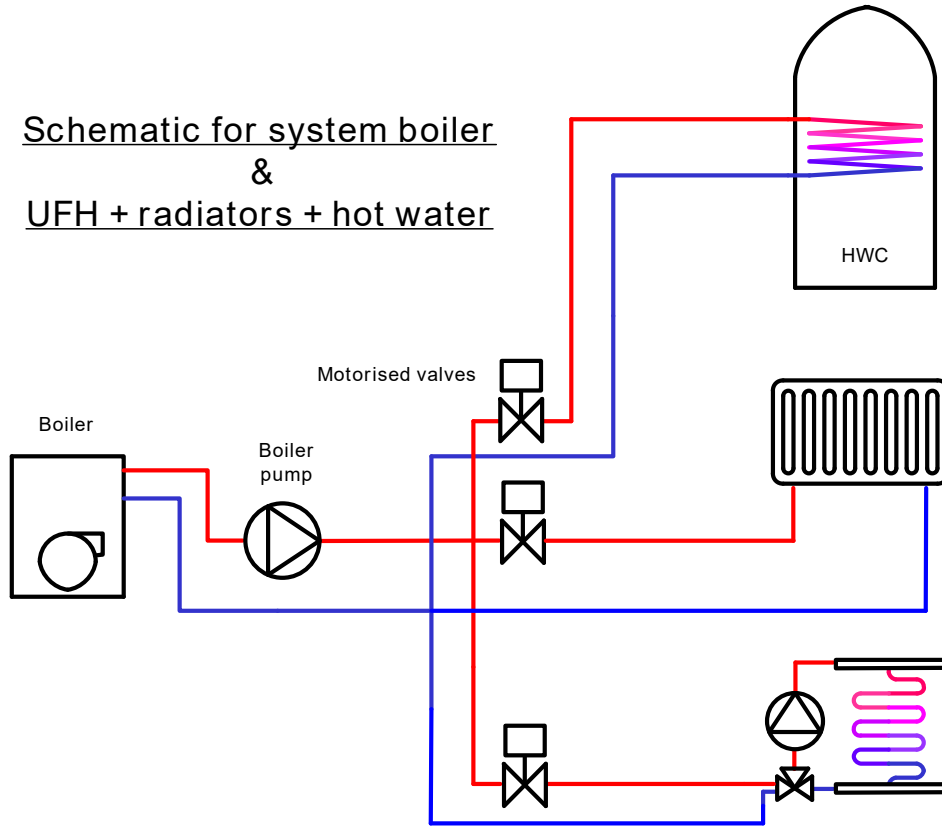

Schematic for gas combination boiler
&
underfloor heating + radiators

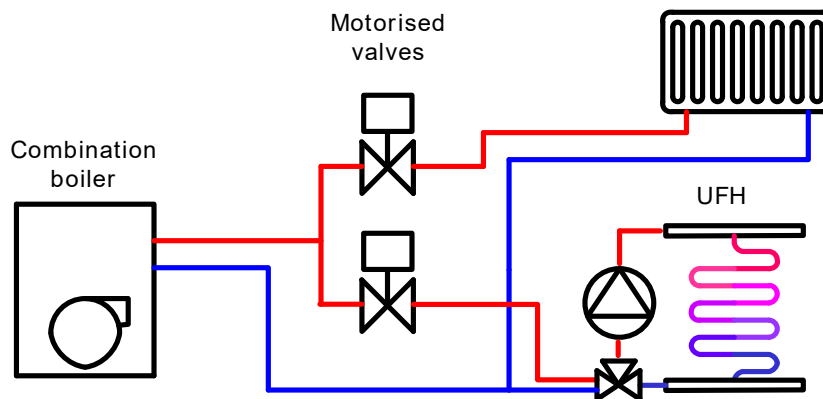

8. Typical Pipe Layout

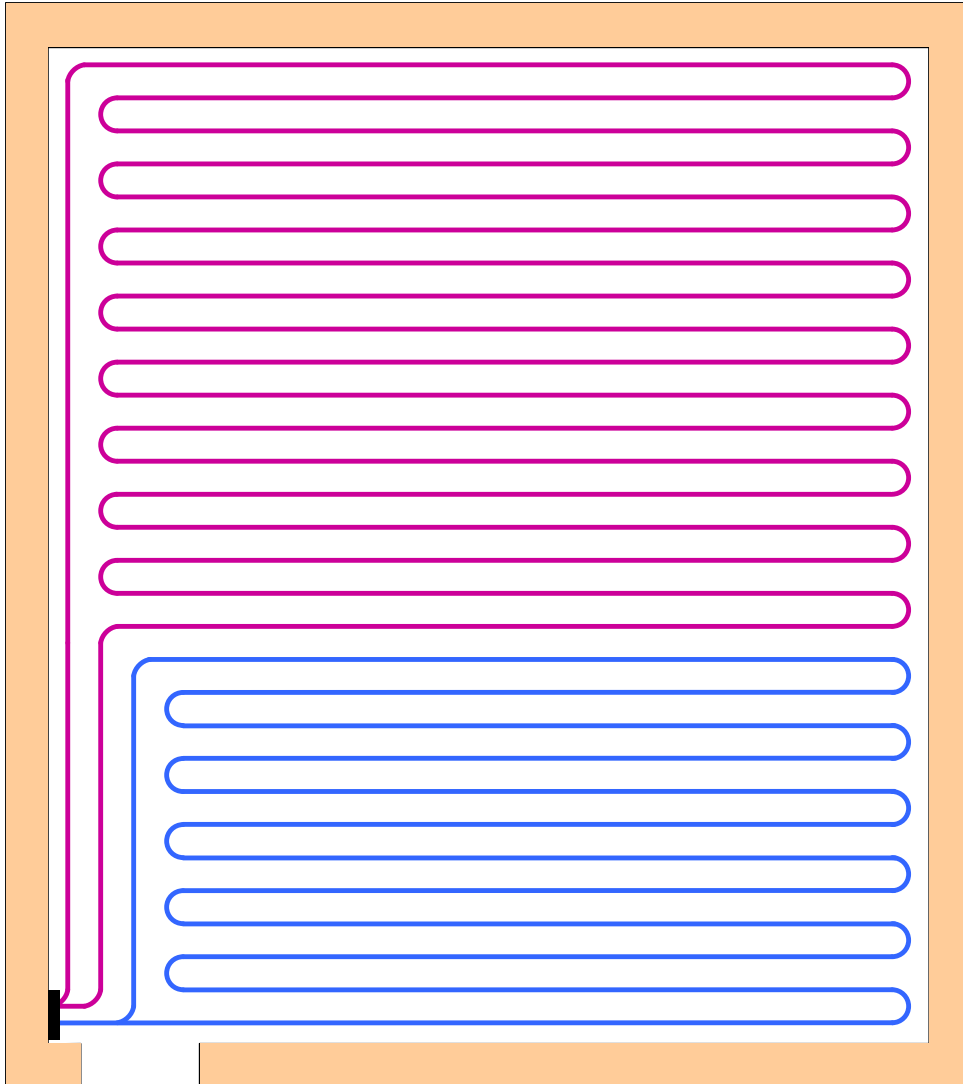

9. Floor Types

Timber Suspended Floor Between Joists

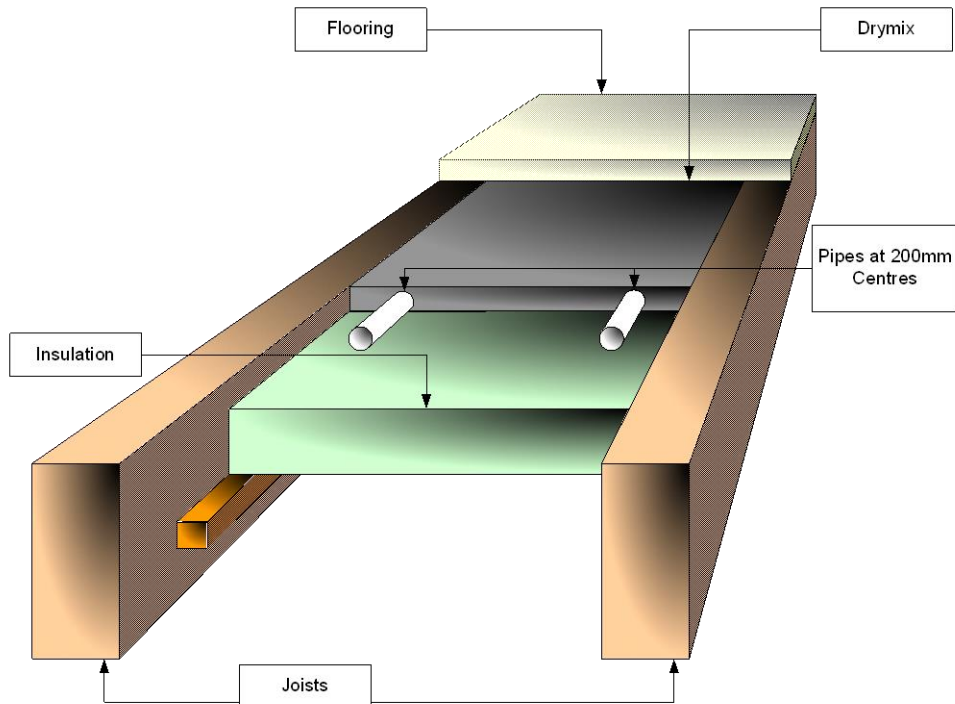

The Drymix is needed for Ground Floor, older buildings and if concrete floor and timber suspended floor are on the same floor. **For First Floor applications when property is built to current building regulations an air gap is fine, still good to use the drymix as will give out more heat.**

Concrete Floor with Staples

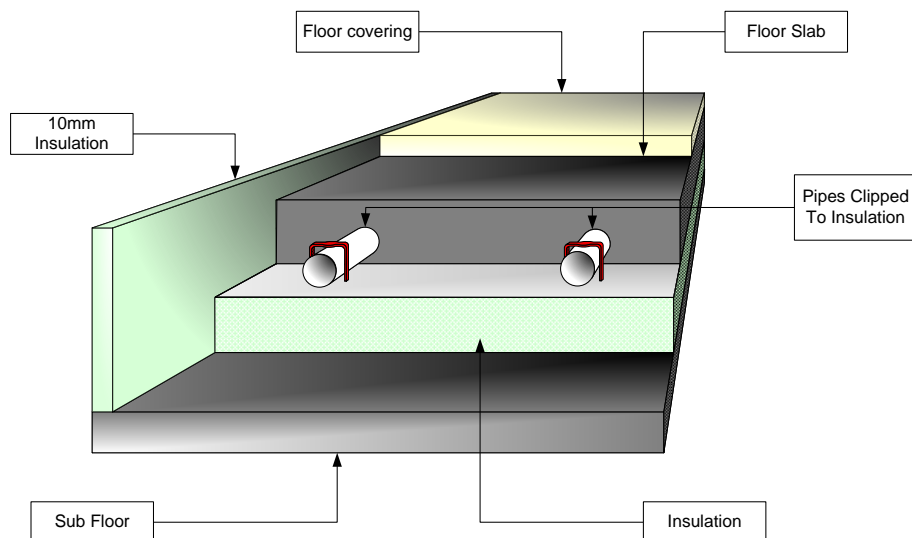

10. Notes.

The Underfloor Heating system can be fitted in both concrete and timber suspended floors. See picture above. For other floor constructions please contact us and we will explain installation procedure, for example you can also do a floating floor. **Note that there are many options for installing underfloor heating in timber suspended floors, please contact us for more information.**

In concrete screeded floors, the screed acts to diffuse the heat across the surface providing an even temperature at the floor surface.

Normally a concrete slab is laid over DPM. A 20 mm thick piece of insulation is fixed to the perimeter walls, to a height to include the depth of floor insulation and screed.

Whilst the edging insulation may be on show it is covered by wall plastering and skirting boards. Use 20 mm Celotex or we can supply the edging insulation.

Floor insulation is laid to the whole area, joints are taped to prevent the ingress of screed between the insulation boards. The floor is now ready for the underfloor heating pipework installation.

We recommend a minimum of 50 mm Polyurethane insulation. If there is not enough space for 50 mm insulation, 30 mm is recommended, but always check that you apply to current building regulations. We recommend Polyurethane as it out performs Polystyrene and it's greater density allows for use of clip fittings.

If you use Polystyrene insulation it is recommended that you install wire mesh D49 on top of the insulation and tie the pipe with cable ties to the mesh.

The pipe is laid at c/c 200 mm centres dependent upon design. Care must be taken to protect the pipework whilst laying the screed. We recommend **65 mm – 75 mm screed to be laid over the pipes and the insulation.** Fibre screed or Anhydrite screed can be 50 mm. Finally the floor finish is added.

Always check with the manufacturer of any floor covering that it can be used for underfloor heating.

Timber suspended floors do not conduct heat as efficiently as screeded floors. This means that the heat output is less.

Some manufacturers use heat emission plates to try and achieve an even temperature on the floor. This is a very expensive way of installing underfloor heating in timber suspended floors and at the end of the plate the temperature is not going to be very high. Clearly there should be a cheaper solution that works without using the very expensive plates. After all, the first floor is usually timber suspended and on the first floor less heat is usually required. Also note that the first floor is supplemented by heat from the ground floor.

Our underfloor heating system is very simple and easy to install in timber suspended floors. The system is based on thousands of installations that are now working with total satisfaction.

Between the joists, a 50 mm Polyurethane insulation board is cut for a tight fit. See picture above. It is advisable to use scrap battens from building site to support the insulation from below.

The pipe is then clipped on the insulation with our special clips. Then the floor boards are laid on top of the joists. Be careful not to leave too much air space between the insulation boards and floor boards (25 mm is recommended). The joists need to be notched where needed for pipe runs.

For ground floor timber suspended or buildings 20 year or older we recommend;

To get the timber suspended floor to act as a screed floor and to give out more heat, the air gap between the insulation and the floor boards should be filled with a lightweight screed mix. This infill is normally also required if you are mixing timber suspended floor and concrete floor on the same floor level.

We recommend the infill for all properties that are not built to current building regulations. The mix consists of 10:1 sand/cement mix or 8:1 Lytag lightweight mix on top of the insulation, with enough water to hold the mix together. The additional load imposed on the floor by the mix is approximate 18 kg/sqm. Note that the mix is not intended as load bearing, merely as a heat conductor. The thickness of the mix should be 25 mm with the pipe included in it.